

**SpaceOps 2004 – Conference – Track 2:**

**Building the Operational System**

# **The Design and Implementation of an Inter-Agency, Multi-Mission Space Flight Operations Network Interface**

R. Byrne<sup>1</sup>, M. Scharf<sup>1</sup>, D. Doan<sup>1</sup>, J. Liu<sup>1</sup>, A. Willems<sup>1</sup>

<sup>1</sup>*Jet Propulsion Laboratory, California Institute of Technology, Pasadena, CA, USA*





# Abstract

- An advanced network interface was designed and implemented by a team from the Jet Propulsion Lab (JPL) with support from the European Space Operations Center (ESOC).
- The interface was implemented to support three ESA missions (INTEGRAL, MEX and Rosetta), and an ESA probe (Huygens) associated with a NASA mission (Cassini).
- The interface between ESOC in Darmstadt, Germany and JPL in Pasadena, California, was conceived with several advanced networking techniques. The objectives for the interface included maximizing network utilization on the circuits shared by the four missions, providing bandwidth guarantees for critical traffic, providing ISDN backup circuits with automatic failover, and using Quality of Service (QoS) techniques to protect Voice over IP (VoIP) traffic.
- This presentation describes the requirements for the interface, the design, the topology, the testing and lessons learned from the whole implementation.



# Introduction

- In early 2002, an interface was conceived to support three ESA missions (INTEGRAL, MEX and Rosetta) and an ESA probe (Huygens) associated with a NASA mission (Cassini).
- A team from JPL as well as their counterparts at ESOC started with laboratory testing of various solutions to the mission requirements and after over a year of testing and engineering, the interface is in normal operations.
- The main design trade-off was with having one pair of devices handle the complex interface, or several. The fewer devices there are make it easier to operate and maintain, but it's harder to get opportunities to make changes to configurations, since more than one project must concur with the window of opportunity schedule requests.



# Functional Requirements

- INTEGRAL data rate: minimum of 256 kbps
- Rosetta data rate: 64 kbps
- MEX data rate: 192 kbps
- Cassini/HPOC data rate: 128 kbps
  
- Voice over IP for all projects except Cassini/HPOC
- Auto failover of primary data circuit to redundant circuit within 5 minutes
- Voice to have priority of link, then high priority data, then low priority data for all projects.
  
- In two pairs, one project should be able to use another project's unused bandwidth (INTEGRAL/Cassini-HPOC, Rosetta/MEX)



# Interface Design

- Two projects per redundant link pair (dedicated with ISDN backup)  
Maximizes network utilization of link, since each project can borrow the other's unused bandwidth. (Cisco CBWFQ technique)
- Multi-Priority data streams treated differently using CBWFQ, high priority given guaranteed bandwidth, low priority gets default treatment.
- Source routing used to steer project data to correct dedicated or redundant link (Cisco route-map technique)
- MLPPP used to get ISDN rates near the primary circuit rates
- Cisco backup-interface auto-failover technique used to get failover times down to less than 10 seconds
- RTP Priority used to guarantee Voice over IP traffic



# Interface Topology

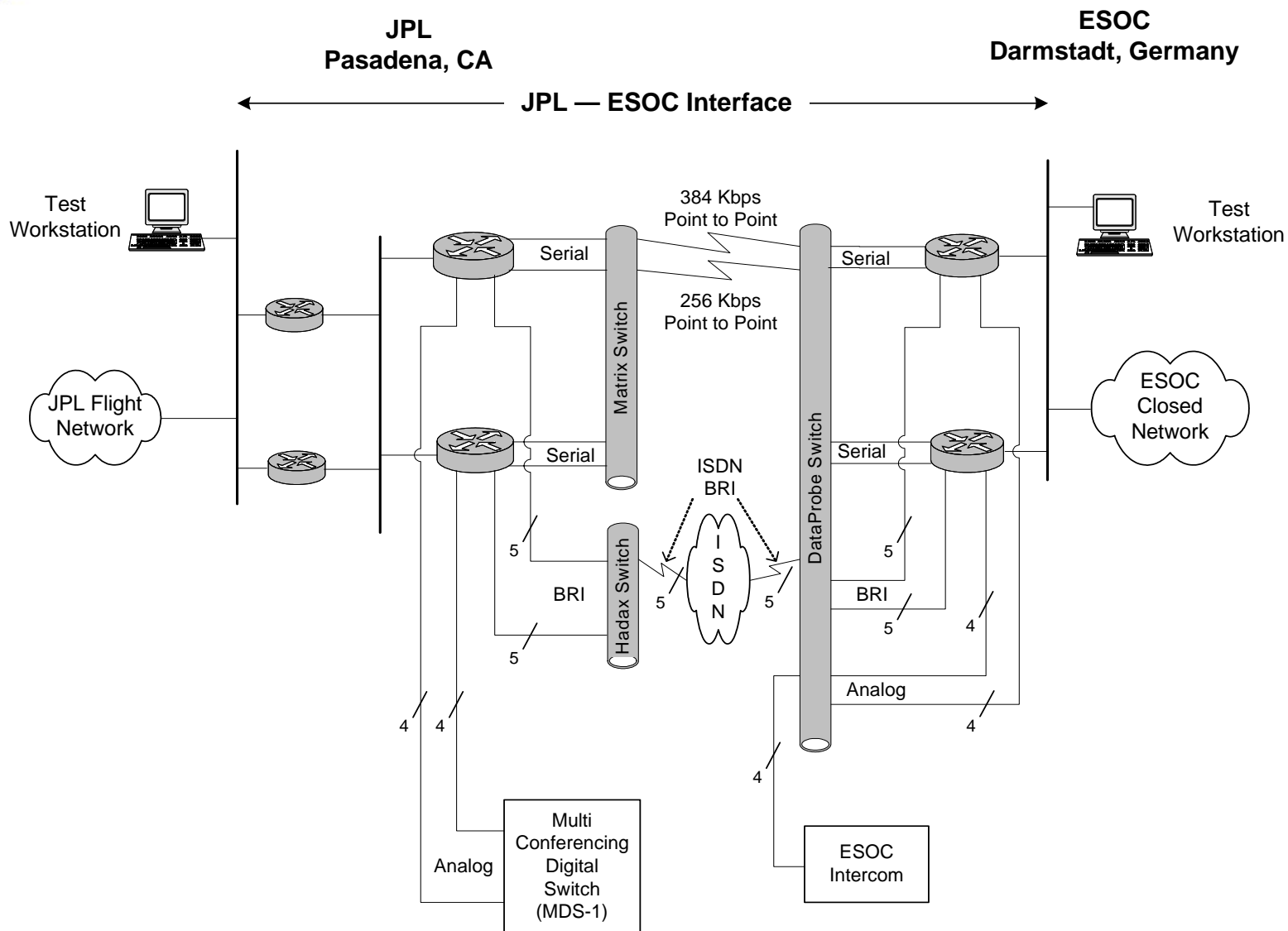



# Interface Testing

## Lab testing:

- Interleave time set in Cisco IOS configuration affects throughput as follows:
  - As interleave time reduced, throughput was also reduced
  - ISDN path results in fragment sizes being smaller, which also hinders throughput
- Other factors found to affect throughput:
  - TCP window size
  - Relative start time of each data stream

## Live testing:

- Difficult to schedule since 4 projects needed to concur with Window Of Opportunity proposals.
- Qualitative (voice = 5x5, voice affects data transfer, but not vice versa)



# Lessons Learned

- Rather than doing source routing (via route-maps):  
Use double-NAT technique (NAT both source and destination)
- Use more scalable solution with three routers on the JPL side  
(used for successor New Norcia Alternate Asset interface)
- Use MLPPP to tie all lines together, yet bill each project for their MLPPP bundle member.
- Remote (and out of band) management of DataProbe switch box would be an improvement.
- CBWFQ traffic trending possible if correct MIBs are obtained.
- Sometimes it seems like one interface box pair per project would be better, since it's so hard to get WOOs. This would of course be very tough to operate!





# Acknowledgements

The authors wish to thank the following people for their help with this work:

- JPL:

- David Carroll
- Yuanis Heathington
- Dwight Holmes
- Jason Liao
- Rick Markley

- ESOC:

- Manfred Bertelsmeier
- Marko Butkovic
- Wolfgang Hell
- Wale Jones
- Paolo Maldari
- Manfred Warhaut



# Glossary

CBWFQ = Class-Based Weighted Fair Queuing

ESOC = ESA Space Operations Center

HPOC = Huygens Probe Operations Center

INTEGRAL = International Gamma-Ray Astrophysics Laboratory

IOS = Internetwork Operating System

ISDN = Integrated Services Digital Network

JPL = Jet Propulsion Lab

MEX = Mars Express

MIB = Management Information Base

MLPPP = Multi-Link Point to Point Protocol

NAT = Network Address Translation

QoS = Quality of Service

RTP = Real-Time Protocol

TCP = Transmission Control Protocol

VoIP = Voice Over IP

WOO = Window Of Opportunity